



BUSINESS BROCHURE

Hollow Profiles Catalog

High Standard Aluminium Extrusion

- Circular Hollow Profiles
- Square Hollow Profiles
- Rectangular Hollow Profiles

CIRCULAR HOLLOW PROFILES

Standard: GB/T 5237、ISO9001

Alloy Material: 6063T5/ 6063T6/ 6061T6

Surface Treatment:

Mill-finished/ Powder coated/ Anodized/ Wooden Grain

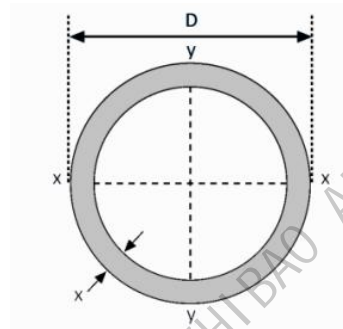

Standard Sectional Dimension		Unit Weight (Kg/m)	Mold's No.:	Standard Sectional Dimension		Unit Weight (Kg/m)	Mold's No.:
Outside Diameter (D/ mm)	Thickness (mm)			Outside Diameter (D/ mm)	Thickness (mm)		
4	Solid	0.034	Y4	12	1.0	0.093	Y12
5.5	Solid	0.065	Y5A		2.0	0.172	Y12A
7.6	Solid	0.124	Y07D		Solid	0.311	Y12J
8	0.9	0.055	Y08F	14	1.1	0.122	Y14E
	1.2	0.07	Y08B		2.5	0.247	Y14G
	1.4	0.079	Y08E		4.25	0.356	Y14A
	Solid	0.137	Y08		Solid	0.420	Y14C
9.7	Solid	0.202	Y10H	14.2	1.5	0.163	Y14D
9.9	1.95	0.131	Y09B	15	1.0	0.120	Y15P
10	1.0	0.077	Y10		2.0	0.223	Y15
	1.2	0.090	Y10B	16.5	1.1	0.144	Y16
	Solid	0.214	Y10G		16	1.2	0.152
11.9	1.0	0.093	Y11F	0.95		0.120	Y16P

CIRCULAR HOLLOW PROFILES

Standard: GB/T 5237、ISO9001

Alloy Material: 6063T5/ 6063T6/ 6061T6

Surface Treatment:

Mill-finished/ Powder coated/ Anodized/ Wooden Grain

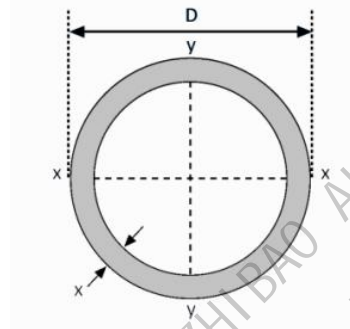

Standard Sectional Dimension		Unit Weight (Kg/m)	Mold's No.:	Standard Sectional Dimension		Unit Weight (Kg/m)	Mold's No.:
Outside Diameter (D/mm)	Thickness (mm)			Outside Diameter (D/ mm)	Thickness (mm)		
18	1.0	0.146	Y18	20	1.8	0.278	Y20H
	1.45	0.206	Y18M		Solid	0.848	Y20B
	Solid	0.687	Y18F	21	1.0	0.172	Y21
18.6	1.0	0.151	Y18N	21.5	3.6	0.553	Y21E
18.9	2.5	0.352	Y18H		4.6	0.667	Y21D
19	0.8	0.125	Y19D	22	1.0	0.180	Y22G
	1.0	0.154	Y19F		1.1	0.197	Y22F
	1.15	0.176	Y19X		1.35	0.239	Y22D
	6.0	0.669	Y19Y		2.0	0.343	Y22K
	Solid	0.766	Y19L		3.0	0.489	Y22
	1.6	0.236	Y19B		Solid	1.045	Y22S
19.5	0.95	0.150	Y19A	22.22	1.0	0.182	Y22A
20	0.9	0.147	Y20C		1.2	0.216	Y22E

CIRCULAR HOLLOW PROFILES

Standard: GB/T 5237、ISO9001

Alloy Material: 6063T5/ 6063T6/ 6061T6

Surface Treatment:

Mill-finished/ Powder coated/ Anodized/ Wooden Grain

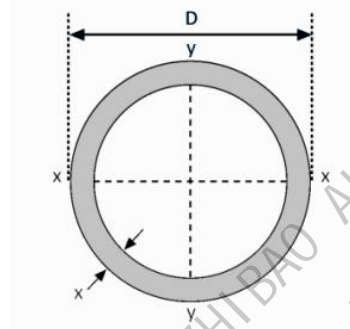

Standard Sectional Dimension		Unit Weight (Kg/m)	Mold's No.:	Standard Sectional Dimension		Unit Weight (Kg/m)	Mold's No.:
Outside Diameter (D/mm)	Thickness (mm)			Outside Diameter (D/ mm)	Thickness (mm)		
24.8	0.8	0.166	Y24G	28	1.15	0.265	Y28A
25	0.9	0.186	Y25P		3.0	0.643	Y28
	1.1	0.225	Y25Z	29	1.2	0.280	Y29A
	1.4	0.280	Y25B		30	0.9	0.222
	1.5	0.302	Y25Q	1.5		0.367	Y30A
	1.8	0.354	Y25K	1.8		0.435	Y30G
	2.5	0.482	Y25D	1.9		0.458	Y30I
	Solid	1.325	Y25Q	2.0		0.475	Y30B
	25.4	1.0	0.207	Y25		3.0	0.695
6.35		1.027	Y25F	Solid	1.944	Y30M	
Solid		1.383	Y25GA	31	1.0	0.257	Y31D
26	9.5	1.330	Y26B		11.4	1.916	Y31
26.8	2.0	0.424	Y27	31.75	0.9	0.238	Y31P
27	1.0	0.223	Y27E	32	1.0	0.266	Y32P

CIRCULAR HOLLOW PROFILES

Standard: GB/T 5237、ISO9001

Alloy Material: 6063T5/ 6063T6/ 6061T6

Surface Treatment:

Mill-finished/ Powder coated/ Anodized/ Wooden Grain

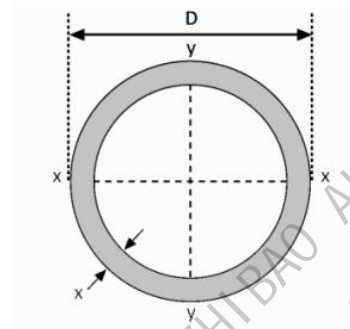

Standard Sectional Dimension		Unit Weight (Kg/m)	Mold's No.:	Standard Sectional Dimension		Unit Weight (Kg/m)	Mold's No.:
Outside Diameter (D/mm)	Thickness (mm)			Outside Diameter (D/ mm)	Thickness (mm)		
32	1.5	0.392	Y32L	38	3.6	1.062	Y38C
	2.1	0.539	Y32H	38.1	1.0	0.315	Y38
	2.3	0.586	Y32A	39	16.5	3.149	Y39B
	3.0	0.746	Y32C	40	4.0	1.221	Y40C
31.7	1.35	Y32B	1.0		0.334	Y40Y	
33.3	1.9	Y33	1.2		0.395	Y40A	
34	2.6	Y34B	5.0		1.512	Y40E	
34.65	2.25	0.618	Y35H	41	6.5	1.923	Y41
35	1.4	0.403	Y35A		11.5	2.910	Y41A
	1.8	0.513	Y35D	42	2.3	0.775	Y42
37.4	1.35	Y37D	3.0		1.003	Y42C	
37.5	0.9	0.283	Y37P		Solid	3.782	Y42B
38	1.5	0.47	Y38A	42.2	1.0	0.353	Y42F
	5.0	1.415	Y38B	45	1.0	0.373	Y45T

CIRCULAR HOLLOW PROFILES

Standard: GB/T 5237、ISO9001

Alloy Material: 6063T5/ 6063T6/ 6061T6

Surface Treatment:

Powder coated/ Anodized/ Wooden Grain

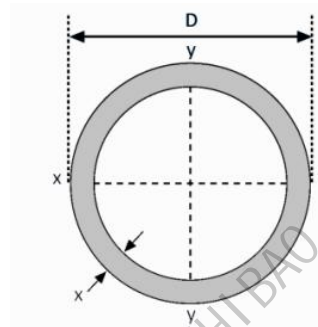

Standard Sectional Dimension		Unit Weight (Kg/m)	Mold's No.:	Standard Sectional Dimension		Unit Weight (Kg/m)	Mold's No.:
Outside Diameter (D/mm)	Thickness (mm)			Outside Diameter (D/ mm)	Thickness (mm)		
45	1.0	0.373	Y45T	50	2.0	1.906	Y50M
	1.2	0.451	Y45E		2.0	0.823	Y50R
	1.5	0.560	Y45C	51	2.0	0.841	Y51
	2.0	0.738	Y45G	54	4.0	1.715	Y54E
46	2.0	0.755	Y46		7.5	2.991	Y54D
42.4	2.9	0.982	Y46C	56	0.9	0.425	Y56
48	3.0	1.158	Y48G		11.5	4.389	Y56A
48.41	4.47	1.685	Y48F	57	9.0	3.705	Y57C
49.5	0.85	0.355	Y49		3.0	1.389	Y57
50	3.0	1.209	Y50AA		4.5	2.026	Y57D
50.8	1.2	0.505	Y50F	58	1.0	0.489	Y58
	1.5	0.637	Y50T	59.7	1.4	0.701	Y59
50	1.0	0.416	Y50G	60	4.0	1.921	Y60B
	1.5	0.627	Y50K		4.65	2.207	Y60F

CIRCULAR HOLLOW PROFILES

Standard: GB/T 5237、ISO9001

Alloy Material: 6063T5/ 6063T6/ 6061T6

Surface Treatment:

Mill-finished/ Powder coated/ Anodized/ Wooden Grain

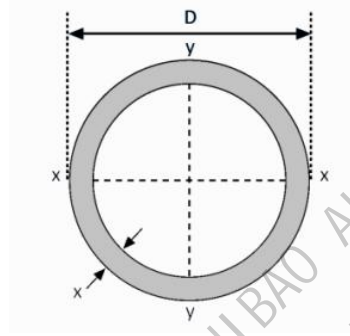

Standard Sectional Dimension		Unit Weight (Kg/m)	Mold's No.:	Standard Sectional Dimension		Unit Weight (Kg/m)	Mold's No.:
Outside Diameter (D/mm)	Thickness (mm)			Outside Diameter (D/ mm)	Thickness (mm)		
61	2.0	1.001	Y61	76	3.2	1.976	Y76H
63	10.5	4.728	Y63	76.1	4.7	2.847	Y76B
63.5	9.0	4.207	Y63A	76.2	6.0	3.613	Y76C
66	3.5	1.876	Y66B	81	3.0	1.985	Y81
	4.5	2.374	Y66A	83	8.0	5.146	Y83
69	13.5	6.426	Y69	84	1.3	0.922	Y84
70	2.0	1.154	Y70	87	2.5	1.812	Y87B
70.2	0.9	0.535	Y70A	88	5.0	3.520	Y88
72	3.0	1.775	Y72A	90	6.0	4.323	Y90
	7.8	4.295	Y72	95	1.4	1.124	Y95A
74	2.5	1.533	Y74		9.75	7.129	Y95C
75	1.6	0.996	Y75B	97	2.75	2.223	Y97
75.5	3.2	1.984	Y76F	98	24.75	15.549	Y98

CIRCULAR HOLLOW PROFILES

Standard: GB/T 5237、ISO9001

Alloy Material: 6063T5/ 6063T6/ 6061T6

Surface Treatment:

Mill-finished/ Powder coated/ Anodized/ Wooden Grain

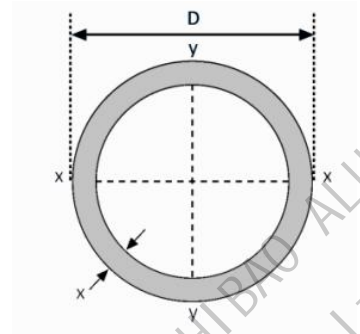

Standard Sectional Dimension		Unit Weight (Kg/m)	Mold's No.:	Standard Sectional Dimension		Unit Weight (Kg/m)	Mold's No.:
Outside Diameter (D/mm)	Thickness (mm)			Outside Diameter (D/ mm)	Thickness (mm)		
76	2.75	1.728	Y76D	140	1.15	1.354	Y140
99.8	4.85	3.950	Y100A	142.6	1.3	1.575	Y142A
101	3.2	2.655	Y101	150	3.5	4.374	LJQ-150
108	4.5	4.024	Y108K	152	2.4	3.101	LJQ-152
	6.0	5.249	Y108	153.3	1.5	1.953	Y150A
110	2.5	2.280	Y110	155	1.3	1.695	Y155
	5.0	4.503	Y110A	155.5	1.4	1.851	Y156
116	3.0	2.876	Y116	160.4	1.6	2.179	Y160
	9.0	8.259	Y116A	160	3.0	4.040	Y160A
117.34	1.17	1.166	Y117A	180	2.5	3.78	LJQ-180
117.6	1.18	1.136	Y118	192	3.5	4.678	LJQ-192
128	2.0	2.161	Y128	200	3.0	5.000	LJQ-200
132	3.0	3.283	Y132	230	5.0	9.649	Y230
141.7	2.0	2.396	Y137H	252	3.5	6.466	LJQ-252

SQUARE HOLLOW PROFILES

Standard: GB/T 5237、ISO9001

Alloy Material: 6063T5/ 6063T6/ 6061T6

Surface Treatment:

Mill-finished/ Powder coated/ Anodized/ Wooden Grain

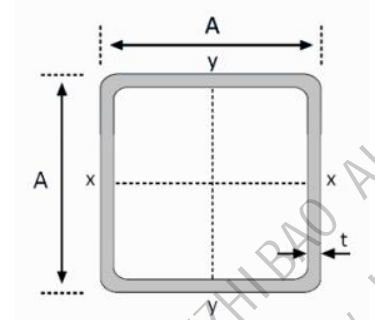

Standard Sectional Dimension		Unit Weight (Kg/m)	Mold's No.:	Standard Sectional Dimension		Unit Weight (Kg/m)	Mold's No.:	
A*A (mm)	Thickness (mm)			A*A (mm)	Thickness (mm)			
10X10	0.9	0.089	G10	18.59X18.5	1.02	0.193	G18A	
	1.5	0.139	G10A		19X19	1.2	0.231	G19
12.7X12.7	1.27	0.159	G12A	19.05X19		1.4	0.266	G19T
	1.1	0.139	G12APT		20X20	0.8	0.158	G19P
	1.0	0.126	G12B			20X20	1.0	0.205
14.7X14.7	1.5	0.216	G14A	20X20	1.1		0.229	G20G
15X15	1.2	0.179	G15		20X20	1.2	0.246	G20D
	0.95	0.144	G15B			20X20	1.3	0.263
	1.4	0.207	G15T	20.5X20.5			1.5	0.302
16X16	0.8	0.133	G16B		20.5X20.5	2.0	0.393	G20H
	1.0	0.164	G16P	24.5X24.5		1.5	0.310	G20T
	1.3	0.209	G16		24.5X24.5	2.0	0.400	G20A
	2.2	0.332	G16A	2.0		0.491	G24A	
18.59X18	1.0	0.201	G18D					

SQUARE HOLLOW PROFILES

Standard: GB/T 5237、ISO9001

Alloy Material: 6063T5/ 6063T6/ 6061T6

Surface Treatment:

Mill-finished/ Powder coated/ Anodized/ Wooden Grain

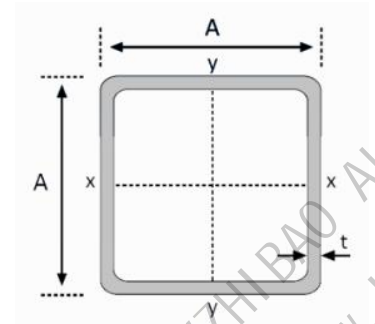

Standard Sectional Dimension		Unit Weight (Kg/m)	Mold's No.:	Standard Sectional Dimension		Unit Weight (Kg/m)	Mold's No.:
A*A (mm)	Thickness (mm)			A*A (mm)	Thickness (mm)		
25X25	1.1	0.286	G25B	32X32	0.8	0.273	G32
	1.5	0.385	G25M		1.8	0.598	G32A
25.4X25.4	0.9	0.241	G25P	37.9X37.9	1.7	0.672	G38C
	1.0	0.263	G25C	38X38	0.9	0.367	G38P
	1.1	0.301	G25L		2.8	1.1076	G38A
	1.2	0.315	G25		3.2	1.216	G38K
	2.0	0.505	G25H		38.1X38.1	1.2	0.478
	3.2	0.767	G25T	1.4		0.555	G38T
30X30	1.0	0.317	G30A	40X40	0.8	0.343	G40G
	1.4	0.441	G30T		1.0	0.426	G40M
	2.0	0.611	G30B		1.1	0.462	G40F
	3.0	0.884	G30D		1.2	0.503	G40
31.7X31.7	1.2	0.400	G31		1.2	0.508	G40C

SQUARE HOLLOW PROFILES

Standard: GB/T 5237、ISO9001

Alloy Material: 6063T5/ 6063T6/ 6061T6

Surface Treatment:

Mill-finished/ Powder coated/ Anodized/ Wooden Grain

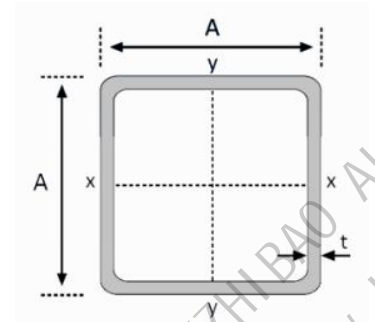

Standard Sectional Dimension		Unit Weight (Kg/m)	Mold's No.:	Standard Sectional Dimension		Unit Weight (Kg/m)	Mold's No.:
A*A (mm)	Thickness (mm)			A*A (mm)	Thickness (mm)		
40X40	1.4	0.590	G40T	50X50	1.4	0.743	G50E
	1.5	0.631	G40Q		1.8	0.937	G50H
	1.7	0.711	G40B		3.0	1.54	G50R
	1.8	0.743	G40H	50.3X50.3	1.35	0.714	G50J
	2.5	1.031	G40L		1.2	0.643	G50
	3.0	1.212	G40K		1.4	0.747	G50T
40.4X40.4	0.85	0.367	G40D	50.8X50.8	1.5	0.800	G50C
40.9X40.9	2.95	1.208	G40E		2.0	1.06	G50A
43.5X43.5	4.0	1.706	G43		2.5	1.304	G50F
45X45	1.2	0.574	G45D	3.0	1.549	G50B	
	2.0	0.946	G45H	55X55	1.0	0.590	G55
50X50	1.15	0.612	G50N		60X60	1.2	0.762
	4.0	2.009	G50AE	1.4		0.886	G60T

SQUARE HOLLOW PROFILES

Standard: GB/T 5237、ISO9001

Alloy Material: 6063T5/ 6063T6/ 6061T6

Surface Treatment:

Mill-finished/ Powder coated/ Anodized/ Wooden Grain

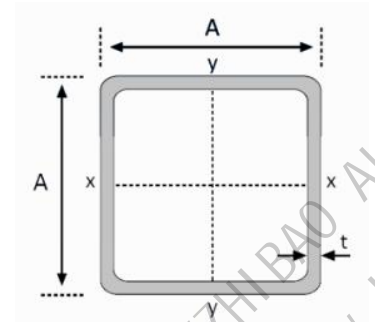

Standard Sectional Dimension		Unit Weight (Kg/m)	Mold's No.:	Standard Sectional Dimension		Unit Weight (Kg/m)	Mold's No.:
A*A (mm)	Thickness (mm)			A*A (mm)	Thickness (mm)		
60X60	2.0	1.253	G60H	80X80	1.2	1.021	G80
	3.0	1.847	G60A		1.4	1.202	G80C
	3.5	2.175	G60F		3.0	2.523	G80D
63.5X63.5	2.0	1.328	G63	2.0	1.685	G80H	
65X65	1.5	1.040	G65A	4.0	3.320	G80E	
	1.8	1.242	G65	85X85	1.0	0.924	G85
67X67	1.8	1.267	G67A	90X90	1.25	1.211	G90
70X70	1.4	1.049	G70T	1.8	1.734	G90A	
75X75	3.0	2.359	G75A	3.0	2.850	G90E	
76.2X76.2	3.0	2.372	G76	100X100	1.2	1.295	G100P
	1.7	1.368	G76H	2.0	2.140	G100M	
	1.5	1.210	G76T	2.5	2.633	G100D	
100X100	5.0	5.187	G100J	101.5X101	3.0	3.194	G100A

SQUARE HOLLOW PROFILES

Standard: GB/T 5237、ISO9001

Alloy Material: 6063T5/ 6063T6/ 6061T6

Surface Treatment:

Mill-finished/ Powder coated/ Anodized/ Wooden Grain

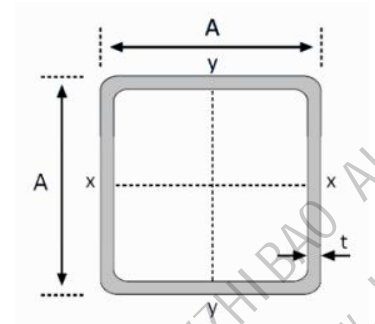

Standard Sectional Dimension		Unit Weight (Kg/m)	Mold's No.:	Standard Sectional Dimension		Unit Weight (Kg/m)	Mold's No.:
A*A (mm)	Thickness (mm)			A*A (mm)	Thickness (mm)		
101.6X101	1.5	1.62	G100T				
	2.0	2.151	G100H				
108X108	1.6	1.859	G108				
120X120	2.0	2.577	G120				
	2.5	3.208	G120A				
130x130	2.0	2.795	LJQ-130A				
	2.5	3.481	LJQ-130B				
	3.0	4.160	LJQ-130C				
135X135	3.0	4.324	G135				
160.5X160	2.8	4.822	G160				
180X180	3.0	5.799	G180A				

RECTANGULAR HOLLOW PROFILES

Standard: GB/T 5237、ISO9001

Alloy Material: 6063T5/ 6063T6/ 6061T6

Surface Treatment:

Mill-finished/ Powder coated/ Anodized/ Wooden Grain

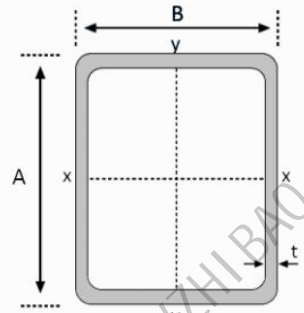

Standard Sectional Dimension		Unit Weight (Kg/m)	Mold's No.:	Standard Sectional Dimension		Unit Weight (Kg/m)	Mold's No.:
A*B (mm)	Thickness (mm)			A*B (mm)	Thickness (mm)		
10X6	1.2	0.089	G106	20X10	0.9	0.139	G2010P
12X9	1.3	0.131	G1209		1.40	0.208	G2010B
14X5.8	1.1	0.107	G1405	20X15	1.0	0.178	G2015P
15X10	1.5	0.181	G1510A		1.5	0.262	G2015
15X12	1.0	0.137	G1512A	22.5X12	1.1	0.194	G2212
	1.2	0.159	G1512	23X12	1.5	0.264	G2312
16X8.8	1.5	0.180	G1608	24X12	1.0	0.186	G2412
18X9	0.8	0.111	G1809	24X13	1.8	0.325	G2413
18X12	0.8	0.124	G1812A	25X8	1.1	0.185	G2508
18.65X12.3	1.37	0.209	G1812	25X12	1.2	0.227	G2512
19X6	0.8	0.101	G1906	25X16	1.2	0.253	G2516
	1.0	0.126	G1906A	25X18	1.1	0.242	G2518
19.05X9.55	0.9	0.130	G1909	25.5X20	1.2	0.282	G2520

RECTANGULAR HOLLOW PROFILES

Standard: GB/T 5237、ISO9001

Alloy Material: 6063T5/ 6063T6/ 6061T6

Surface Treatment:

Mill-finished/ Powder coated/ Anodized/ Wooden Grain

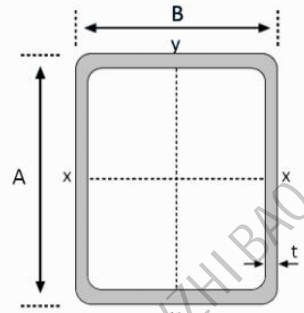

Standard Sectional Dimension		Unit Weight (Kg/m)	Mold's No.:	Standard Sectional Dimension		Unit Weight (Kg/m)	Mold's No.:
A*B (mm)	Thickness (mm)			A*B (mm)	Thickness (mm)		
27X20	2.0	0.464	G2720	30X20	2.0	0.502	G3020D
28X20	1.0	0.248	G2820P		0.9	0.237	G3020B
29.5X15.3	1.2	0.278	G2915		1.15	0.302	G3020E
29.8X19.8	1.1	0.282	G2919P	30.3X30.3	1.0	0.265	G3021
	1.3	0.33	G2919	30X22	3.0	0.753	G3022A
30X10	1.5	0.303	G3010		1.0	0.27	G3022
30X15	0.9	0.212	G3015P	30X25	1.2	0.345	G3025
	1.25	0.286	G3015		2.0	0.557	G3025A
	1.5	0.340	G3015T	30X29	1.8	0.538	G3029
	2.0	0.451	G3015C	31X9	1.2	0.246	G3109
30X16	1.5	0.355	G3016T	33X20	1.8	0.486	G3320
30X20	1.2	0.308	G3020	35X30	2.0	0.660	G3035
	1.5	0.381	G3020H	35X8	1.0	0.224	G3508

RECTANGULAR HOLLOW PROFILES

Standard: GB/T 5237、ISO9001

Alloy Material: 6063T5/ 6063T6/ 6061T6

Surface Treatment:

Mill-finished/ Powder coated/ Anodized/ Wooden Grain

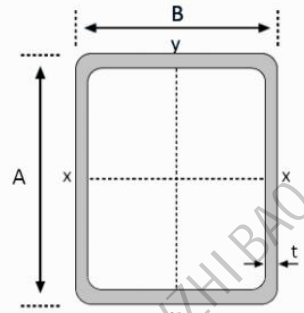

Standard Sectional Dimension		Unit Weight (Kg/m)	Mold's No.:	Standard Sectional Dimension		Unit Weight (Kg/m)	Mold's No.:
A*B (mm)	Thickness (mm)			A*B (mm)	Thickness (mm)		
35X18	1.2	0.333	G3518	40X20	0.9	0.283	G4020P
37.5X24.5	0.8	0.261	G3724		1.1	0.347	G4020
37.8X24.6	0.65	0.214	G3724A		1.7	0.520	G4020H
38X10	1.1	0.275	G3810		2.0	0.612	G4020E
38X25	0.85	0.284	G3825AP	0.8	0.255	G4020F	
	1.0	0.333	G3825BP	40X25	1.2	0.410	G4025A
	1.6	0.522	G3825T		1.75	0.581	G4025P
38X25	1.4	0.460	G3825Q	40X30	1.2	0.443	G4030
38.1X25.3	1.1	0.364	G3825P		3.00	1.056	G4030B
	1.0	0.338	G3825PA	41.3X27.3	2.5	0.859	G4228
38.1X25.4	1.23	0.405	G3825	42X16	2.0	0.590	G4216
39.8X19.6	0.9	0.280	G3919P	44X25	1.0	0.366	G4425P
40X10	1.8	0.456	G4010A		1.27	0.456	G4425

RECTANGULAR HOLLOW PROFILES

Standard: GB/T 5237、ISO9001

Alloy Material: 6063T5/ 6063T6/ 6061T6

Surface Treatment:

Mill-finished/ Powder coated/ Anodized/ Wooden Grain

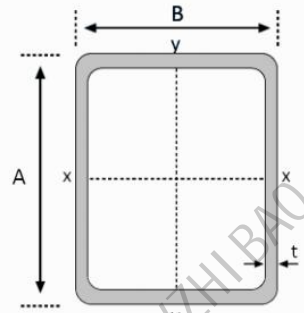

Standard Sectional Dimension		Unit Weight (Kg/m)	Mold's No.:	Standard Sectional Dimension		Unit Weight (Kg/m)	Mold's No.:
A*B (mm)	Thickness (mm)			A*B (mm)	Thickness (mm)		
44X25	1.8	0.643	G4425A	50.8X25.4	1.0	0.401	G5025P
45X25	2.5	0.887	G4525	50.9X25.4	1.2	0.479	G5025
50.9X12	1.5	0.485	G5012		1.4	0.560	G5025T
50X19	1.2	0.436	G5019		3.0	1.139	G5025D
50X20	1.2	0.443	G5020E	49.8X24.8	2.50	0.957	G5025R
	1.4	0.514	G5020D	50X30	1.2	0.508	G5030D
50X25	0.9	0.360	G5025F		1.4	0.590	G5030E
	1.0	0.394	G5025A		1.7	0.703	G5030H
	1.15	0.456	G5025L	3.0	1.20	G5030	
	1.2	0.476	G5025C	1.90	0.790	G5030G	
	1.4	0.552	G5025K	50.7X38	1.2	0.560	G5038
	2.0	0.775	G5025H	50.8X38	3.2	1.440	G5038D
50.5X25.3	1.5	0.596	G5025B	50.8X38.1	0.9	0.428	G5038B

RECTANGULAR HOLLOW PROFILES

Standard: GB/T 5237、ISO9001

Alloy Material: 6063T5/ 6063T6/ 6061T6

Surface Treatment:

Mill-finished/ Powder coated/ Anodized/ Wooden Grain

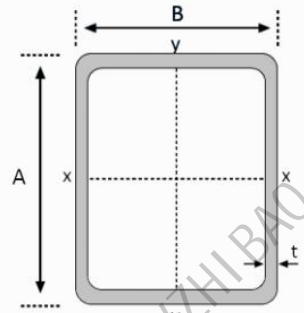

Standard Sectional Dimension		Unit Weight (Kg/m)	Mold's No.:	Standard Sectional Dimension		Unit Weight (Kg/m)	Mold's No.:
A*B (mm)	Thickness (mm)			A*B (mm)	Thickness (mm)		
50X40	1.1	0.522	G5040	60X30	1.2	0.574	G6030
	1.2	0.568	G5040A		2.0	0.939	G6030B
	1.4	0.659	G5040		1.0	0.480	G6030F
	2.0	0.912	G5040D		1.0	0.529	G6040P
	2.8	1.290	G5040E		60X40	1.2	0.639
52X24	1.8	0.704	G5224		2.0	1.036	G6040
52X30	1.8	0.762	G5230	65X15	1.6	0.671	G6515
54X31	1.2	0.541	G5431A	65X20	1.2	0.541	G6520A
55X45	2.0	1.037	G5545A	65X35	1.5	0.785	G6535
60X20	1.2	0.503	G6020	65.6X27	0.8	0.397	G6520
	2.0	0.821	G6020H	70X10	2.0	0.830	G7010
60X25	1.4	0.621	G6025T	70X20	1.8	0.84	G7020
60X25.4	1.2	0.540	G6025	70X25	0.93	0.468	G7025P

RECTANGULAR HOLLOW PROFILES

Standard: GB/T 5237、ISO9001

Alloy Material: 6063T5/ 6063T6/ 6061T6

Surface Treatment:

Mill-finished/ Powder coated/ Anodized/ Wooden Grain

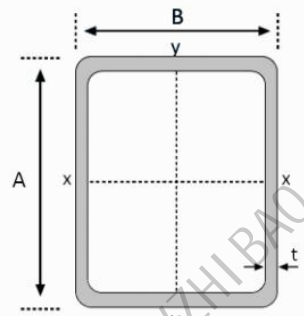

Standard Sectional Dimension		Unit Weight (Kg/m)	Mold's No.:	Standard Sectional Dimension		Unit Weight (Kg/m)	Mold's No.:
A*B (mm)	Thickness (mm)			A*B (mm)	Thickness (mm)		
70X25	0.93	0.468	G7025P	76X44	1.15	0.739	G7644M
	1.25	0.624	G7025		1.8	1.144	G7644E
70X30	1.6	0.836	G7030	76X50	1.8	1.190	G7650
70X35	2.3	1.247	G7035		2.0	1.332	G7650B
	70X50	2.0	1.103	G7035A	76.2X25.4	1.0	0.538
3.0		1.847	G7050	1.2		0.643	G7625
1.4		0.896	G7050A	1.4		0.750	G7625T
1.2	0.771	G7050B	2.0	1.054		G7625H	
72X31	1.2	0.652	G7231	2.8		1.468	G7625A
73X18	0.8	0.390	G7318	76.2X44.5	1.0	0.648	G7644P
75X15	1.4	0.660	G7515		1.2	0.767	G7644
75X40	2.8	1.672	G7540		1.4	0.891	G7644T
75X50	3.0	1.928	G7550		1.8	1.138	G7644H

RECTANGULAR HOLLOW PROFILES

Standard: GB/T 5237、ISO9001

Alloy Material: 6063T5/ 6063T6/ 6061T6

Surface Treatment:

Mill-finished/ Powder coated/ Anodized/ Wooden Grain

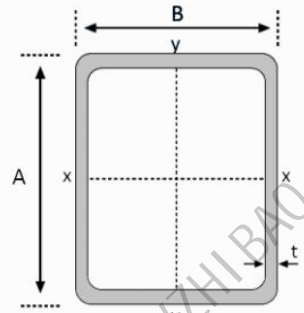

Standard Sectional Dimension		Unit Weight (Kg/m)	Mold's No.:	Standard Sectional Dimension		Unit Weight (Kg/m)	Mold's No.:	
A*B (mm)	Thickness (mm)			A*B (mm)	Thickness (mm)			
76.2X44.5	2.0	1.260	G7644A	80X25	1.35	0.754	G8025B	
	2.5	1.562	G7644B		80X40	0.85	0.549	G8040P
	3.0	1.858	G7644C			1.0	0.644	G8040C
76.4X22	1.1	0.593	G7622			1.4	0.896	G8040A
76.4X41.4	1.2	0.758	G7641		2.0	1.267	G8040Q	
80X12	1.5	0.721	G8012	2.5	1.552	G8040		
80X15	0.9	0.461	G8015P	80X44	1.0	0.659	G8044P	
80X20	0.8	0.456	G8020P		1.2	0.817	G8044	
	1.5	0.794	G8020		1.4	0.926	G8044T	
	3.0	1.551	G8020B		2.0	1.310	G8044A	
80X25	1.0	0.556	G8025P	80X50	1.4	0.972	G8050	
	1.05	0.590	G8025D		2.0	1.376	G8050B	
	1.15	0.638	G8025		3.0	2.031	G8050H	

RECTANGULAR HOLLOW PROFILES

Standard: GB/T 5237、ISO9001

Alloy Material: 6063T5/ 6063T6/ 6061T6

Surface Treatment:

Mill-finished/ Powder coated/ Anodized/ Wooden Grain

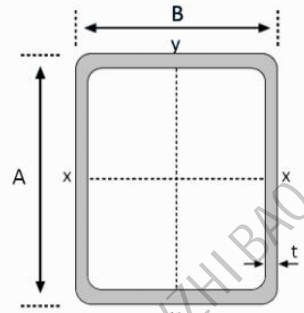

Standard Sectional Dimension		Unit Weight (Kg/m)	Mold's No.:	Standard Sectional Dimension		Unit Weight (Kg/m)	Mold's No.:
A*B (mm)	Thickness (mm)			A*B (mm)	Thickness (mm)		
80X60	2.0	1.485	G8060	90X25	1.6	0.966	G9025H
80X65	2.5	1.911	G8065	90X28	2.0	1.254	G9028
82X22	0.85	0.475	G8222X	90X44	1.3	0.922	G9044
	0.9	0.502	G8222P		1.0	0.721	G9044A
84X54	1.4	1.033	G8454		1.4	1.003	G9044T
86.8X18	1.0	0.561	G8618		3.0	2.097	G9044B
88X25	1.0	0.599	G8825P	90X60	1.4	1.113	G9060
	1.2	0.717	G8825	92X25	1.6	0.983	G9225
88.5X58.5	4.0	3.036	G8858	95X30	2.0	1.321	G9530
90X20	0.9	0.532	G9020P	96X23	1.1	0.694	G9623
90X25	1.0	0.599	G9025P	97X57	3.0	2.424	G9757
	1.2	0.738	G9025	99X43	1.8	1.345	G9943
	1.4	0.848	G9025T	100X15	0.9	0.560	G10015P

RECTANGULAR HOLLOW PROFILES

Standard: GB/T 5237、ISO9001

Alloy Material: 6063T5/ 6063T6/ 6061T6

Surface Treatment:

Mill-finished/ Powder coated/ Anodized/ Wooden Grain

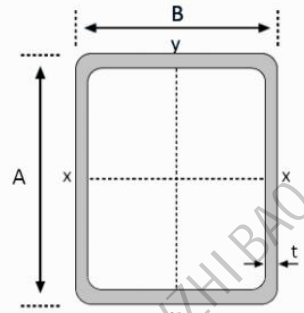

Standard Sectional Dimension		Unit Weight (Kg/m)	Mold's No.:	Standard Sectional Dimension		Unit Weight (Kg/m)	Mold's No.:
A*B (mm)	Thickness (mm)			A*B (mm)	Thickness (mm)		
100X15	1.6	0.977	G10015	100X40	1.0	0.759	G10040P
	0.9	0.581	G10020P		2.0	1.485	G10040C
100X20	1.0	0.644	G10020	100X44	1.15	0.890	G10044M
	1.9	1.205	G10020B		1.4	1.087	G10044B
100X24	1.8	1.296	G1024	2.0	1.529	G10044A	
	2.0	1.310	G1024A	100X50	1.2	0.967	G1050X
100X25	5.0	3.140	G10025C		1.4	1.113	G1050T
100X30	1.3	0.904	G10030	2.0	1.580	G1050	
	1.8	1.229	G1030	2.5	1.958	G1050H	
100X32	1.0	0.710	G10032	3.0	2.333	G1050D	
100X35	3.0	2.090	G1035	4.0	3.067	G1050F	
100X38	1.8	1.331	G10038H	7.0	5.198	G10050A	
	2.3	1.688	G10038A	1.7	1.361	G1050A	

RECTANGULAR HOLLOW PROFILES

Standard: GB/T 5237、ISO9001

Alloy Material: 6063T5/ 6063T6/ 6061T6

Surface Treatment:

Mill-finished/ Powder coated/ Anodized/ Wooden Grain

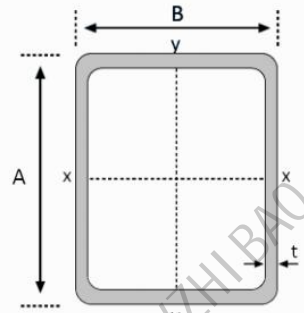

Standard Sectional Dimension		Unit Weight (Kg/m)	Mold's No.:	Standard Sectional Dimension		Unit Weight (Kg/m)	Mold's No.:	
A*B (mm)	Thickness (mm)			A*B (mm)	Thickness (mm)			
100X60	1.8	1.537	G1060A	101.6X44.5	1.0	0.778	G1044P	
	2.0	1.685	G1060		1.2	0.931	G1044	
100X65	1.8	1.586	G10065		1.4	1.083	G1044T	
	3.0	2.604	G10065A		1.6	1.235	G1044H	
100X70	3.0	2.657	G1070		1.8	1.400	G1044A	
100X72	1.4	1.279	G1072		2.0	1.535	G1044B	
100X75	1.7	1.575	G1075		2.5	1.926	G1044D	
101.6X2	1.0	0.675	G1025P		3.0	2.270	G1044F	
	1.2	0.807	G1025		101.6X76.2	1.4	1.338	G1076
	1.4	0.939	G1025T		110X44	1.4	1.143	G11044
	1.8	1.199	G1025H	110X60	2.0	1.793	G11060	
	2.5	1.647	G1025HT	110X65	2.0	1.847	G1165	
	3.0	1.960	G1025A	110X108	3.0	3.473	G110108	

RECTANGULAR HOLLOW PROFILES

Standard: GB/T 5237、ISO9001

Alloy Material: 6063T5/ 6063T6/ 6061T6

Surface Treatment:

Mill-finished/ Powder coated/ Anodized/ Wooden Grain

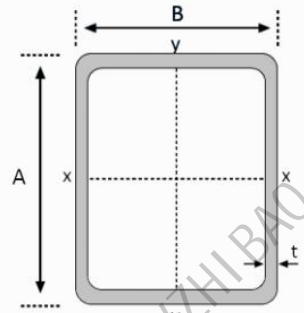

Standard Sectional Dimension		Unit Weight (Kg/m)	Mold's No.:	Standard Sectional Dimension		Unit Weight (Kg/m)	Mold's No.:
A*B (mm)	Thickness (mm)			A*B (mm)	Thickness (mm)		
112X30	2.0	1.507	G11230	120X60	1.6	1.528	G1260
115X25	2.0	1.485	G11525		1.8	1.734	G1260A
120X25.4	1.2	0.927	G1225		2.0	1.922	G12060D
120X30	1.2	0.967	G12030		3.0	2.850	G12060B
	1.6	1.292	G12030A	120X65	2.5	2.457	G12065A
	1.3	1.046	G12030B	120X75	2.0	2.085	G12075
120X40	1.5	1.272	G1240T	120X80	2.0	2.117	G1280T
	1.55	1.313	G1240	125X44	1.8	1.625	G12544
	2.0	1.704	G1240H	125X50	2.5	2.321	G12550
	3.8	3.162	G1240A	126.5X16.6	1.5	1.147	G12616
120X45	2.0	1.758	G12045A	130X30	1.8	1.537	G13030
	2.85	2.479	G12045	130X58	1.4	1.400	G1358
120X50	2.5	2.252	G12050	140X25.4	1.2	1.050	G1425

RECTANGULAR HOLLOW PROFILES

Standard: GB/T 5237、ISO9001

Alloy Material: 6063T5/ 6063T6/ 6061T6

Surface Treatment:

Mill-finished/ Powder coated/ Anodized/ Wooden Grain

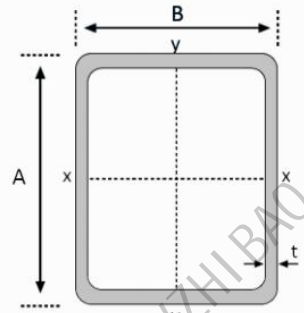

Standard Sectional Dimension		Unit Weight (Kg/m)	Mold's No.:	Standard Sectional Dimension		Unit Weight (Kg/m)	Mold's No.:
A*B (mm)	Thickness (mm)			A*B (mm)	Thickness (mm)		
140X25.4	1.4	1.229	G1425T	150X60	1.3	1.483	G15060A
140X25	2.0	1.739	G1425A		2.2	2.470	G15060B
140X65	1.8	1.979	G14065		2.5	2.798	G15060C
					3.0	3.341	G15060
140X80	1.8	2.127	G14080	150X70	2.0	2.376	G15070A
146X41.3	1.6	1.608	G14641	150X75	2.0	2.387	G1575
150X20	1.3	1.197	G15020		1.8	2.176	G1575P
150X30	2.0	1.922	G15030B	150X100	1.8	2.422	G150100A
	3.0	2.850	G15030		2.3	3.082	G1510
150X40	1.3	1.340	G15040		6.0	7.797	G150100B
150X45	2.0	2.06	G1545	160X25	1.6	1.588	G16025
150X50	1.5	1.613	G15050PA	160X80	2.0	2.577	G16080
	3.0	3.143	G15050	170X50	4.0	4.630	G17050
150X60	1.3	1.483	G15060A	170X70	2.0	2.577	G17070

RECTANGULAR HOLLOW PROFILES

Standard: GB/T 5237、ISO9001

Alloy Material: 6063T5/ 6063T6/ 6061T6

Surface Treatment:

Mill-finished/ Powder coated/ Anodized/ Wooden Grain

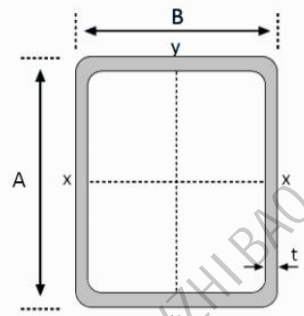

Standard Sectional Dimension		Unit Weight (Kg/m)	Mold's No.:	Standard Sectional Dimension		Unit Weight (Kg/m)	Mold's No.:
A*B (mm)	Thickness (mm)			A*B (mm)	Thickness (mm)		
170X75	2.0	2.632	G17075	250X80	2.5	4.505	LJQ-25080A
178X70	2.5	3.317	G17870	250X80	3.0	5.405	LJQ-25080B
190X76	2.5	2.816	G19076	250X100	3.0	5.733	LJQ-25010A
200X60	2.0	2.839	G20060	250X100	4.0	6.552	LJQ-25010B
200x60	3.0	4.259	LJQ-20060	250X150	3.5	7.644	LJQ-250150
200x80	2.0	3.058	LJQ-200802	250X200	3.9	9.582	LJQ-250200
200x80	3.0	4.586	LJQ-200803	300X80	3.0	6.224	LJQ-30080
200x100	2.0	3.276	LJQ-20010A	300X100	3.5	7.510	G300100
200x100	2.5	4.095	LJQ-20010B	300X120	3.5	8.026	LJQ-300120
200x100	2.8	4.586	LJQ-20010C	300X150	3.5	8.600	LJQ-300150
200X100	3.0	4.851	G200100B	300X200	4	10.880	LJQ-300200
200X150	2.5	4.778	LJQ-20015A	400X100	4.5	12.240	LJQ-400100
200X150	2.8	5.351	LJQ-20015B	400X200	5.75	18.768	LJQ-400200
200X150	3.0	5.635	G200150	500X100	6.0	19.584	LJQ-500100
250X50	3.0	4.914	LJQ-25050	500X200	5.0	19.040	LJQ-500200